



## C3 - INDEX PULSE BOARD Rev. 5.1

### Overview

### Features

This card provides easy way of capturing the pulse signal from photo-transistor and transmitting it to the parallel port.

- ***Reads an index pulse from the spindle.***
- ***Acts as an optical switch for accurate homing.***
- ***Comes with a Built-in LED that shows the status of the output pin at all times.***
- ***Comes with 6' pre-wired shielded cable.***
- ***Easy connections.***

Just put the Photo-Transistor in place, connect the board to the power supply, and attach the signal output to an input pin from the parallel port.

- ***All TTL 5VDC signals.***

Interface directly with parallel port interface products and other cnc4pc cards. 5VDC (TTL) signals are very common among automation devices.

- ***Screw-On connections for all terminals.***

You only have to screw-on the wires to make all your connections.

- ***Comes with an RJ45 Connector fast installation.***

With this connector you just have to plug in an standard RJ45 cable and will not require further wiring. For more info go to: <http://cnc4pc.com/RJ45.htm>.

## ***Uses:***

**Threading on a Lathe.**

**Configure a tachometer on your software.**

**Use per-rev speed feeds, instead of per-min.**

**Using it as an optical limit or homing switch.**

*You can place the phototransistor at the end of travel of an axis to use it as a limit or homing switch.*

## **Installation**

Please read your software's manual for configuring your setup. Keep in mind that with Mach you can use more than one pulse per revolution for increased accuracy. If you are using Mach, might have to adjust your debounce settings to obtain accurate readings.

## ***Requirements:***

- It requires a 5VDC power supply to operate.
- You must provide a disk with perforations on the side to provide the reading for the phototransistor.

## Wiring.

Please note the wiring diagram bellow.

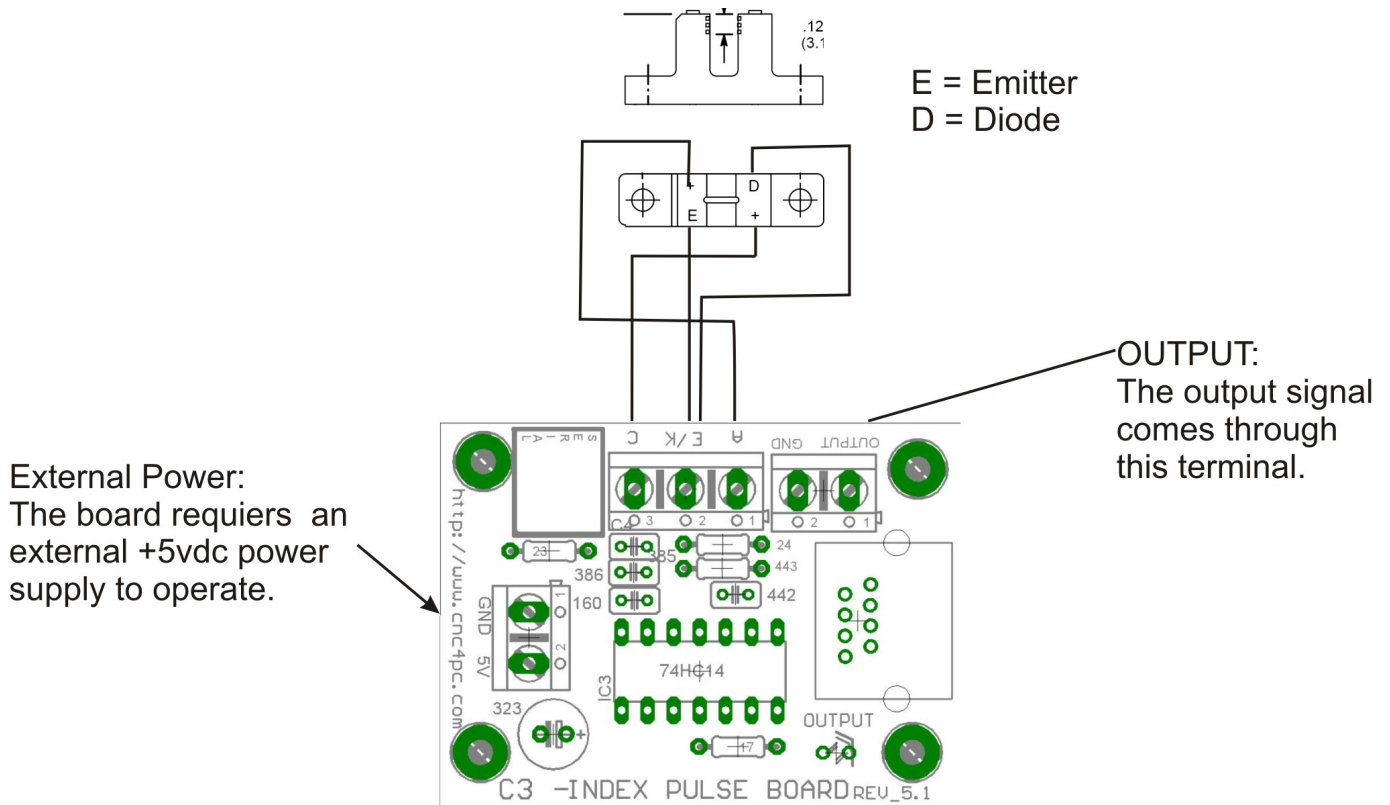

In many cases the photo-transistor provided would not be suitable for your application. In most cases it could be replaced for other photo transistors. For example, you can use a reflective photo-transistor, and placing a piece of tape on the spindle.

## RJ45 Connector:

The RJ45 connector is for connecting the boards directly using a standard RJ45 cable. A standard RJ45 cable has straight through wiring. That means that Pin1 = Pin1, etc...

This Connector is been provided in many of our boards and soon we will have breakout boards that will come with this connectors. This is to ease the installation process by eliminating the screw on terminals. The RJ45 connectors are used not just to carry the I/O signals, but also to power the external board. That way you will have it all in one connection.

The main I/O is carried in pin4 of the RJ45 connector.

The type of connection is +5vdc, just as the signal coming out of the terminal.

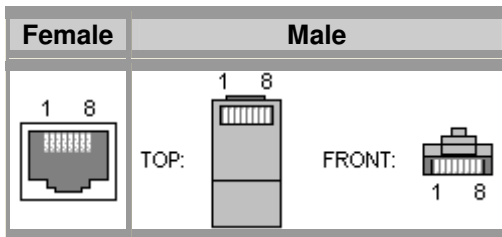

Pin	Description
1	+12vdc
2	+5vdc
3	NC1
4	NC2
5	NC3
6	NC4
7	NC5
8	GND

### ***Tuning:***

Test the card by connecting the photo-transistor, the power supply, and a LED in the output pins. The LED should light each time the photo-transistor is activated.

### **Performance:**

Max Speed	15Khz.
Voltage	5 VDC
Integrated Circuit	LM339 and HD74LS04

For more information consult the circuit's Datasheet at:

<http://cnc4pc.com/TechDocs/LM339.pdf> and <http://cnc4pc.com/TechDocs/HD74LS04.pdf>

## Dimensions:

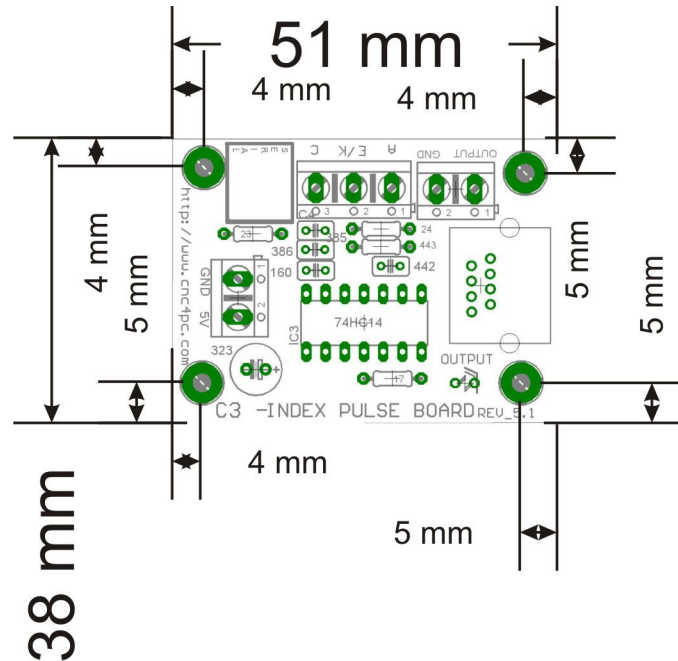

## Disclaimer:

Use caution. CNC machines are dangerous machines. DUNCAN USA, LLC or Arturo Duncan are not liable for any accidents resulting from the improper use of these devices.